

Design and Development of GSR Biofeedback Device

Maryam Hashemi

MSc., Department of Biomedical Engineering, Science and Research Branch,
Islamic Azad University, Tehran, Iran

Abstract

It has been a long time that human is interested in learning how to control involuntary actions such as heartbeat, blood pressure, breathing, etc., so a lot of research has been done on this issue so far. One of the methods using in this field is biofeedback, in which someone can roughly control an involuntary action or having better control over some voluntary actions such as muscle contraction through some visual or audio feedback from those actions. This study is to design and development of one biofeedback instrument, which is GSR (Galvanic Skin Response), and examine some signals that have been taken by this device.

Keywords: Galvanic skin response (GSR), biofeedback, signal acquisition, relaxation training, lie detection

1. Introduction

We have always thought that our mind is in our brain but there is much scientific evidence that shows our mind is in our whole body and our brain is just a simple control center. This even explains the phenomenon that every living cell reacts to all our thoughts and feelings. Moreover, this phenomenon makes biofeedback significantly effective. Through this feedback, we can teach people to be relaxed and healthy by control their thoughts and feelings [9]. Despite the human interest in gaining control and changing physical actions using mental factors, biofeedback expression had not invented until 1969 when the first US biofeedback association meeting was held. And there were not significant scientific experiments about the relation between mind and body. Biofeedback has not been accepted by many psychologists until Miller who worked on operant conditioning with animals indicated in 1969 that some physiological actions which were thought to be involuntary can be controlled. Other studies also showed that using biofeedback, it is possible to gain more control over the autonomic nervous system. This control also included heartbeat, Weiss, and Engel in 1971, and blood pressure, Benson, Shapiro, Tursky, and Schwartz in 1971, [5]. Many specialists from psychologists to dentists, nurses, and physiotherapists use biofeedback as a tool for treatment. Patients are taught various forms of relaxation training. They learn to detect the circumstances, which cause disease symptoms in them and how they can cope with stressors or avoid them. Most of them are encouraged to change some of their habits and to gain more self-control through some special techniques [2]. Different types of biofeedback are EMG, EEG, GSR, HRV, and respiration.

The first time that GSR was mentioned in psychological research was in “studies in word analysis” written by Carl Gustav Jung in 1906. In this book, the Swiss psychologist explained a

method in which a patient's skin impedance is measured by an instrument with some electrodes that are connected to their hand. It works as words in a list are read to an individual one by one, if one of the words in the list has sentimental value, skin impedance will change and it causes GSR device pointer to move. Words, which make greater responses in GSR instrument than usual, determine the fields that caused discomfort for the person. These fields will be examined in detail in psychotherapy sessions. Jung used the GSR device as a display to determine the proper track for everyone's treatment [6]. Today, GSR device is used in items like physiological biofeedback, lie detection, measurement of stress, arousal and emotional excitement level, measurement of response level to different stimuli and relaxation training [4]. Skin resistance or its converse, conductance, can be described as two forms of Tonic and Phasic. A tonic response usually is called Skin Resistance Level (SRL) or its converse Skin Conductance Level (SCL). phasic response is resistance or conductance changes according to events that happen. These changes usually are called Skin Resistance Response (SRR) or its converse, Skin Conductance Response (SCR). These phasic changes are often simply called GSR [7].

According to the electrical circuit model of sweat glands, which was presented by Edelberg in 1972, sweat ducts act as a group of variable resistors that are connected parallel to each other beneath the skin. Considering sympathetic nervous system activity caused by an emotional event or mental stress, sweat amount in these ducts is increased and when ducts are filled with different amounts of sweat a path is created in stratum corneum. Hence, when sweating increases, resistance decreases in variable resistors and creates a more conductive path. The level of this conductance corresponds to sweat amounts in sweat ducts as well as the number of activated sweat glands. Therefore, the resistance changes that are recorded and measured by GSR depend on mental and emotional changes in everyone. Since, Eccrine glands density is more in palms of hands and soles of feet rather than other parts of the body, GRS signal recording and measurement is usually done from the palm of the hand [3].

This study aim is to design and develop of GSR device which can be used for stress level detection and relaxation training. For doing this constant current source method was used to measure skin resistance level and changes which were then displayed on both a computer screen and an LED bar-graph. Moreover, some signals which were taken by this instrument will be examined as well in two fields of relaxation training and lie detection. The rest of this paper is organized as follows. In section II, hardware and software parts of the instrument are explained in detail. In section III, some signals which have been recorded by this device in relaxation state and lie detection will be illustrated and analyzed and section IV is the conclusion of our work.

2. GSR Acquisition

Generally, GSR recording is done in two ways of applying constant current and measurement of skin resistance level (SRL) and its changes (SRR), or applying constant voltage and measurement of skin conductance level (SCL) and it changes (SCR). In the constant voltage method, only skin resistance level and voltage source internal resistor limits the current, so it should be careful to prevent passing excessive current through people's bodies that have low skin resistance levels. While, in the constant current method, the current is always the same regardless of one's skin resistance level. Although Direct current (DC) is often used for resistance changes measurement, alternating current can also be used for GSR recording. No frequency range has been determined for this purpose yet. Mclendon and Hemingway (1930)

observed that resistance changes which obtained by DC current applying are 45 times greater than changes measured in 1.5 MHz frequency. Daroge and Nicholes used 60 Hz, Tolles and Carberry used 5 Hz and Taylor used 65 Hz frequency. Faroge and Nicholes stated that GSR amplitude decreases with frequency increase and there is an insignificant response for frequencies more than 1 KHz. They found that the obtained response for 60 Hz frequency was half of the measured response for DC current.

Similar results reported by Yokota and Fujimori in 1962 stating that impedance changes amplitude decreases by frequency increase. Regardless of physiological issues, increasing current amplitude generates a greater GSR signal. Nevertheless, physiological issues restrain the current increase. Edelberg made an experiment in this field in 1960. He demonstrated that skin resistance response (SRR) increases linearly with current up to the current density of $11\text{pA}/\text{Cm}^2$ but with a current density of $100\text{pA}/\text{Cm}^2$, SRR reduces to one fourth. Hence, a current density of $10\text{pA}/\text{Cm}^2$ seems to be suitable [8].

Considering the above-mentioned, in this research, a DC constant current source was used to measure the skin resistance amount and its changes. A schematic block diagram of the system design is provided in Figure 1.

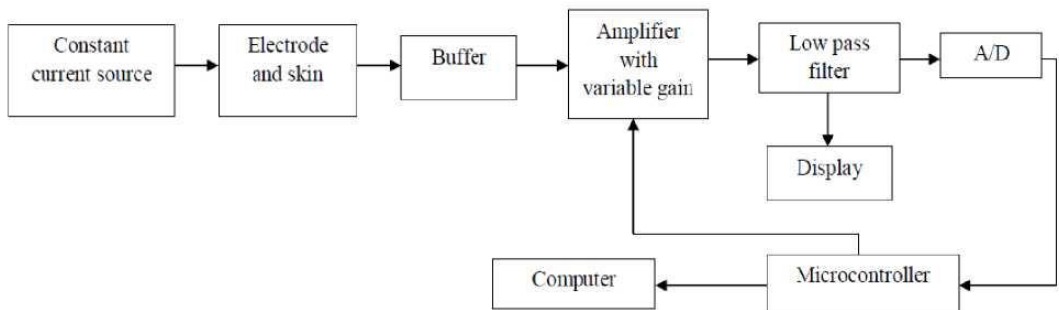

Figure: Block diagram of system design.

Current Source

The current source should cover the following features; 1) It should be able to generate very small currents like 10pA. 2) It should be designed for loads connected to the earth, meaning this current source load should not be float. 3) Current passing through the load should be independent of load resistance value. It means, considering skin resistance changes during the experiment, the current should remain constant and does not change. 4) Current should be acceptably stable and if the experiment takes a long time, the current does not drop.

Considering the above points, here in this project current source IC LM334Z is used. This IC is a tripod IC that can generate the current range of 1pA-10mA and applying voltage range is 1V-40V. The accuracy of the current amount generating by this IC is $\pm 3\%$. This current source has a high output resistance, so current generated by this IC is completely independent of load resistance value and up to 1MQ resistance or even a bit more, the current is completely stable. It also can be used for loads connected to the ground. It is acceptably stable and in the case of a long time experiment, there is no drop in current amplitude. Moreover, using the circuit in figure 2, this current source does not depend on thermal changes.

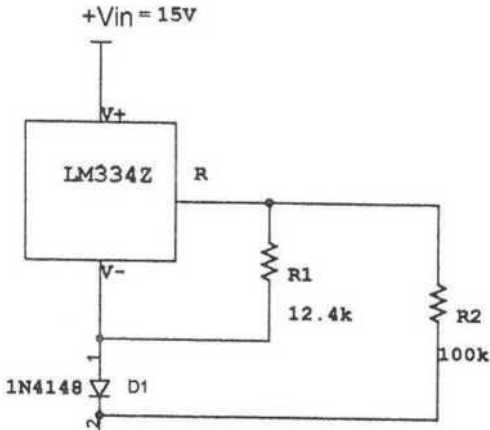

Figure 2. The current source with removing thermal coefficient.

Electrodes

In this project, for skin resistance measurement, we use the index and middle fingers. Therefore, it is needed to use electrodes that are flexible and able to form with hand's fingers, so it is possible to pass current generated by current source to all parts of the skin surface of the two mentioned fingers. For GSR recording Ag/AgCl electrodes are usually used [8]. Unfortunately, since there was no flexible Ag/AgCl electrode in the market that can form around the finger, in this project we made some electrodes with aluminum foil and used them for GSR recording. A picture of them can be seen in figure 3. Furthermore, to decrease noise and signal improvement, shielded wires were used. Here, for increasing resistance changes amplitude, we did not use electrolyte (gel).



Figure 3. Electrodes [1].

Amplifier

The obtained voltage from the skin is passed through a buffer before it enters into the amplifier. It is for impedance matching for optimal voltage transmission. The output signal

from the buffer enters into a variable gain amplifier. The reason for using a variable gain amplifier is to select suitable gain for everyone according to their skin resistance level so that we can observe skin resistance changes more accurately. Here, the AD526 chip which is a programmable amplifier is used. This amplifier provides 1,2,4,8,16 gains and is also compatible with TTL logic. AD526 programming has done by the microcontroller.

Filter

Observing amplifier output in an oscilloscope, too much noise can be seen in it. The dominant noise in the GSR signal is 50Hz noise. Since GSR has a low frequency, for removing this noise, a low pass filter with 1HZ cut off frequency was used. The second-order type of active Butterworth filter was chosen since it has the flattest response in passband compared to other active filters.

Analog to digital converter

Since the GSR signal and its changes are finally displayed on the computer, recorded analog voltage from the skin which has been passed through amplifier and filter, should be converted to digital. For this AD574A chip was used which is a 12-bit A/D. Using a 12-bit A/D instead of an 8-bit one is to achieve higher resolution in resistance measurement. For instructing AD574A to get data and convert them, a microcontroller is used. And 20Hz sampling frequency was selected for this A/D.

Microcontroller

Microcontroller functions include 1) Reading data from A/D. 2) Increase or decrease amplifier gain regarding instruction. 3) Sending information to the computer through the parallel port. 4) Display gain increase or decrease on 7-segment. 5) Instructing buzzer and LED to indicate incorrect electrodes connection to the skin.

In this project for doing the above, 89C51 microcontroller was used.

Seven segment

Next to the gain increase and decrease buttons, there is a 7-segment in the circuit which shows 0 to 4 as five gains which are created by the amplifier. This 7-segment is driven by a BCD decoder which receives related instructions to show numbers on 7-segment from the microcontroller.

Display

For GSR biofeedback instrument being able to both connect to the computer and display GSR signal and its changes by computer software and work independently especially when there is no access to a computer, a display is also improvised in this instrument design. This display continues working while connecting to the computer. LM3914 chip is used for this display. LM3914 is a bar-graph driver that drives 10 LEDs. This IC mechanism is to receive analog voltage and according to voltage level creates a linear analog display.

Power supply

In order to provide needed voltage for ICs in the circuit, a power supply should be designed. These voltages include +15V, -15 V, and +5V. A transformer with 16Vrms was used in this circuit. then, one on/off key for switching system on and off and a 1.5A diode bridge for rectifying were used. To generate +15V, -15V, and +5V, 7815, 7915, and 7805 regulators were

used respectively. The 7805 and 7915 regulators receive their input from 7815 regulator output. In this power supply, because of running current of some ICs and to prevent too much heating, three 7805 regulators were used. How regulators provide voltage for ICs in the circuit is as below:

+15V and -15V for current source IC, amplifier, A/D and, op-amps.

+5V for LEDs driver and bar-graph LEDs.

+5V for microcontroller and buzzer.

+5V for the amplifier, A/D, and 7-segment driver.

A green LED for making sure the proper function of the negative power supply and a red LED for making sure the proper function of the positive power supply were also used in the power supply circuit.

Computer programming

The general purpose of computer programming is to display the GSR signal and its changes. For this, Labview as graphic software was used. The reason for choosing this software is its high ability as well as being easy to use it while working with the parallel port, in addition to its significant graphic features in the signal display as a graph. Generally, the major tasks of the computer program in this project are as below:

Instruct microcontroller for sending information to the computer.

Receiving information sent by the microcontroller through the parallel port.

Converting read voltage from skin to resistance by multiplying it to a proper coefficient.

Display the GSR signal graphically on a chart.

Proper change of graph scale to display according to selected gain.

Display of GSR signal changes in another graph. In this section, GSR signal changes have calculated every second and are displayed on a chart.

Display amplifier gain.

Blinking a software LED which is called ALARM in case of excessive gain increase. Here, if the gain is increased to the extent that the GSR signal cannot be displayed regarding one's skin resistance level, ALARM which is a software LED starts blinking, until the gain is decreased one step and the signal can be displayed, then LED stops blinking.

3. Data Analysis

GSR biofeedback instrument has various types of laboratory and clinical functions such as free association test, lie detection, different conditioning experiments, more effective and faster learning of relaxation training methods, stress control and coping with it, control and decrease anxiety and treatment of lots of phobias, stutter treatment and decreasing blood pressure. Usually, along with biofeedback, different relaxation training methods and autogenetic training are also used. Among these, biofeedback plays a significant role in the acceleration and stability of positive results of treatment.

In this section, we will examine some of the laboratory functions of GSR including effective

factors in GSR changes as well as lie detection. Here, the relaxation factor influence on the GSR signal will be checked. In our experiment, after connecting electrodes to middle and index fingers and setting up the device, first, we wait for 1 to 2 minutes until the person's skin resistance level is stable. Then, we ask people to loose their body's muscles, close their eyes, and try to become relaxed and comfortable. The sample recorded signal for this experiment can be seen in figure 4. As it is shown in the figure, during relaxation, the GSR signal starts to increase and the graph of changes also shows positive values which indicate an upward trend of GSR curve. After a while people are asked to stop being relaxed and return to the normal state, at this moment as it is seen in the figure, the GSR curve falls suddenly and skin resistance returns approximately to its initial value. The changes graph also shows this downward trend by illustrating negative values. As it is obvious in figure 4, reaching to relaxation state takes a longer time than getting out of it, which confirms the point that gaining relaxation is more difficult than losing it and it takes more time. As it is shown in Figure 4, skin initial resistance is 53KQ and after relaxation, it reaches 90KQ. And after asking the person to get out of comfort state, their skin resistance drops to about 54KQ.

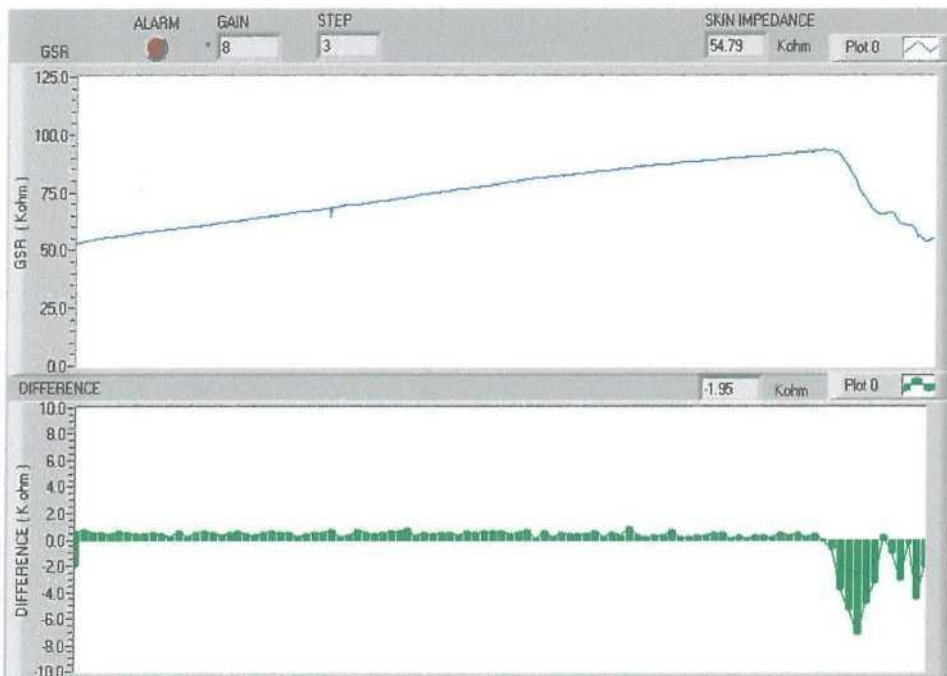

Figure 4. Sample of GSR signal and its variations when experimenting relaxation effect on this signal.

Lie detection is one of the other GSR instrument functions. Here in this study, this function was also examined. The experiment which is done for lie detection test is to ask people to select a number between 1 to 10 without mentioning it. Then, while recording GSR signal and its changes, 1 to 10 numbers will be read aloud for the people randomly and they are asked to say “no” in response to all numbers, even if that number was the one they have chosen. In this experiment, it was observed that when one replies “no” falsely in response to the number they have chosen, the GSR signal shows the most variations. Actually, this experiment was

successful only in 50% of cases. As a matter of fact, environmental conditions are noticeable effective factors for this experiment which play an important role in the success or failure of that. And these conditions need to be controlled the same in all experiments. As can be seen in figure 5, points in change graph which are marked by an arrow, are related to the time when the person replies “no” to the number he/she has selected. As you can see in these points, the GSR signal shows the most changes.

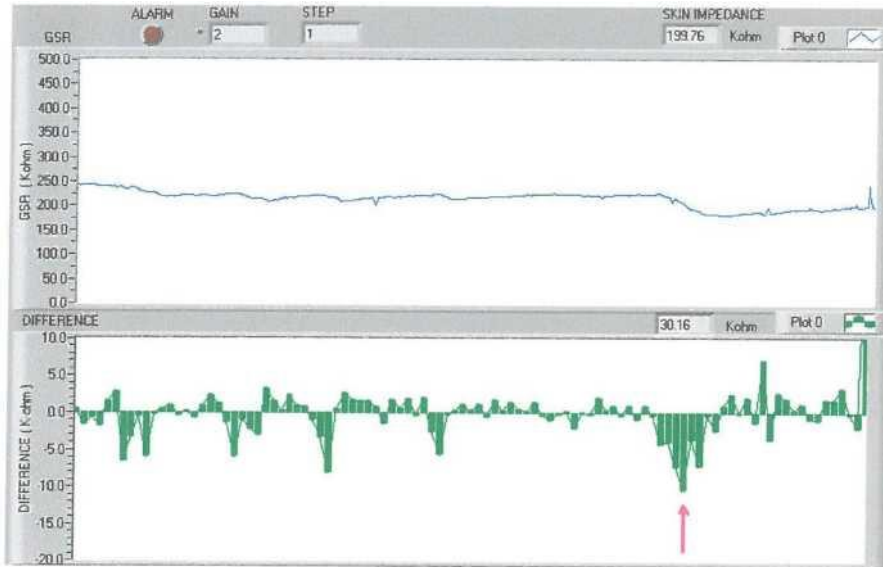

Figure 5. GSR signal sample and its variations in the lie detection test.

4. Conclusion

This research is about the design and development of the GSR biofeedback instrument. Its function in biomedical engineering is relaxation training and voluntary control over the sympathetic part of the autonomic nervous system. In this regard, first, biofeedback was thoroughly explained and then GSR was investigated from different aspects such as physiology, the mechanism of action, and recording and measurement methods. Next, the hardware and software design of the device was described in detail. Finally, samples of recorded signals by the developed device in different functions were analyzed.

According to GSR device ability to illustrate the level of sympathetic nervous system stimulus, using this instrument, it is possible to detect many conditions and provocations which cause stimulus and one usually does not know about them and subsequently, if needed, they can do proper treatment to change or improve the behavior. Therefore, GSR can be used in both diagnosis and treatment areas. Proper use of GSR biofeedback and required training, it is possible to achieve some degrees of control over the sympathetic nervous system and consequently factors that are affected by it like heart rate and blood pressure.

For further studies we recommend below improvements:

Adding the ability to work with a battery.

Automatic data analysis by device software, for instance in lie detection and determining the most variations.

Calculating some GSR signal parameters such as amplitude, delay, rising time, minimum, and maximum.

Displaying words for free association test on the computer monitor and recording GSR signal and its variations at the same time.

Providing audio feedback like playing music by software.

References

- [1] *Galvanic Skin Response*. [Online] Available:
[http://wikid.io.tudelft.nl/WikID/index.php/Galvanic Skin Response](http://wikid.io.tudelft.nl/WikID/index.php/Galvanic_Skin_Response)
- [2] Kay, R., What is biofeedback. [Online] Available:
<https://psvchotherapv.com/bio.html>
- [3] Liew, S. P., (2001), Monitoring Galvanic Skin Responses in Functional Magnetic Resonance Imaging
- [4] MP 100 Electrodermal Response (EDR), (2016), [Online] Available:
<https://www.biopac.com/wp-content/uploads/app187.pdf>
- [5] O’Hair, D. E. (1998). Biofeedback: Review, history and, application. [Online] Available: <http://members.cts.com/crash/d/deohair/psychoph.html>. (June 3,1998)
- [6] Shepherd, P., The Galvanic Skin Response (GSR) Meter, [Online] Available:
<http://www.hackcanada.com/ice3/wetware/gsr.htm#Bilateral>
- [7] Wagner, P., Wagner, T., The Galvanic Skin Response, (2016), iWorks System, Inc.
- [8] Webster, J. G. (1998). Medical instrumentation applied and design. (3rd ed.).
- [9] Wiley What is biofeedback. [Online] Available:
<http://www.lindaland.com/DPPD/biofeed1.htm#a>